

承认书

APPROVAL SHEET

产品名称: 多层片式陶瓷电容器

pART NAME: MULTILAYER CERAMIC CAPACITORS

系 列: 通用系列 (4V~50V)

SERIES : General purpose Series (4V~50V)

产品规格: 0201 ~ 1812

SPECIFICATION: 0201 ~ 1812

品 牌 (BRAND) : 利容

发布日期 (ISSUED DATE): 20220308

批 准 (APPROVED BY):

目录

一、MLCC 简介 General Introduction.....	4
二、MLCC 介质种类 MLCC Dielectric Types.....	4
三、MLCC 产品尺寸与结构 Product Size and Structure.....	5
1、产品尺寸 Product size.....	5
2、产品结构 Product Structure.....	5
四、温度系数/特性 Temperature Coefficient /Characteristics.....	5
五、产品规格表示方法 Part Number Structure.....	6
六、产品范围、尺寸、厚度 Product Range、Size & Thickness.....	8
① I类介质电容范围 (C0G/C0H)	8
② II类介质电容范围 (X7R)	10
③ II类介质电容范围 (X7S).....	12
④ II类介质电容范围 (X6S).....	12
⑤ II类介质电容范围 (X5R)	13
七、包装 Package.....	14
1、产品厚度和包装数量 Thickness and packing Amount.....	14
2、带式圆盘包装 Tape and Reel package.....	14
3、纸带卷盘结构 Paper Taping.....	15

4、塑胶卷盘结构	Embossed Taping	16
5、传送带的前后结构	Front end and Back end Structure of Carrier Tape	17
6、卷盘尺寸	Reel Dimensions (unit: mm)	17
7、纸带性能	Performance of Taping	18
8、外箱包装	Packing	18
八、储存方法	Storage Methods	19
九、使用前的注意事项	Precautions For Use	19
1、焊接的条件与相关图表	Soldering profile	19
2、推荐焊料用量	Recommended Soldering amounts	20
十、推荐焊接温度曲线图	The temperature profile for soldering	21
十一、电气特性	Electrical Characteristics	22
十二、性能测试方法		23

一、MLCC 简介 General Introduction

片式多层陶瓷电容器 (MLCC) 是适合于表面贴装技术 (SMT) 的小尺寸、高比容、高精度陶瓷介质电容器, 可贴装于印刷线路板 (PCB)、混合集成电路 (HIC) 基片, 有效地缩小电子信息终端产品 (尤其是便携式产品) 的体积和重量, 提高产品可靠性, 顺应了 IT 产业小型化、轻量化、高性能、多功能的发展方向。陶瓷电容器适合厂家高密度、高效表面贴装。

Multi-layer ceramic chip capacitor is a kind of ceramic dielectric capacitor with small size, high capacitance per volume, high accuracy, suited surface mounted technology (SMT). It is widely used in electronic circuitry, mounted printed circuit board, and hybrid IC. These different functions require specific capacitor properties.

二、MLCC 介质种类 MLCC Dielectric Types

产品采用的介质材料可以分为两大类:

I类陶瓷介质电容器, 称为高频电容器, 包括通用型高频 COG、COH 电容器和温度补偿型高频 HG、LG、PH、RH、SH、TH、UJ、SL 电容器。高频电容器具有极高的稳定性, 其中 COG、COH 电容器电性能几乎不随时间、交流信号、外加直流偏压的变化而改变, 同时具有极低介质损耗, 即高 Q 值。适用于低损耗、温度补偿型电路中。

II类陶瓷介质陶瓷电容器, 包括 X5R、X6S、X7R、X7S、X7T 介质材料的电容器, 具有较高的介电常数, 容量比I类电容器高, 具有较稳定的温度特性, 更宽的容量范围, 适用于一般电路中, 如隔直、耦合、旁路、鉴频等电路中。

The dielectric materials used in the products can be divided into two broad categories:

Class I dielectric ceramic capacitors, called high-frequency capacitors, including general purpose high-frequency COG, COH capacitors and temperature-compensated high-frequency HG, LG, PH, RH, SH, TH, UJ, SL capacitors. High-frequency capacitors have a very high stability, where COG, COH capacitor electrical performance almost does not change over time, AC signal, plus DC bias, while having very low dielectric loss, that is, high Q value. Suitable for low-loss, temperature-compensated circuits.

Class II dielectric ceramic capacitors, including X5R, X6S, X7R, X7S, X7T dielectric material, Class II dielectric capacitors, with a higher dielectric constant, higher capacitance than Class I capacitors, with stable temperature characteristics, with a wider range of capacitance, In general circuit, such as DC blocking, coupling, bypass, frequency discriminator and other circuits.

三、MLCC 产品尺寸与结构 Product Size and Structure

1、产品尺寸 Product size

型号 Type		尺寸 Dimensions (mm)			
英制表示 British	公制表示 Metric	L	W	T	L ₁ / L ₂
0201	0603	0.6±0.03	0.3±0.03	0.3±0.03	0.15±0.10
0402	1005	1.00±0.05	0.50±0.05	0.50±0.05	0.25±0.10
0603	1608	1.60±0.10	0.80±0.10	0.80±0.10	0.30±0.10
0805	2012	2.00±0.20	1.25±0.20	≤0.55	0.50±0.20
				0.80±0.20	
				1.00±0.20	
1206	3216	3.20±0.30	1.60±0.30	0.80±0.20	0.60±0.30
				1.00±0.20	
				1.20±0.20	
1210	3225	3.20±0.30	2.50±0.30	≤2.80	0.60±0.30
1812	4532	4.50±0.40	3.20±0.30	≤3.50	0.60±0.30

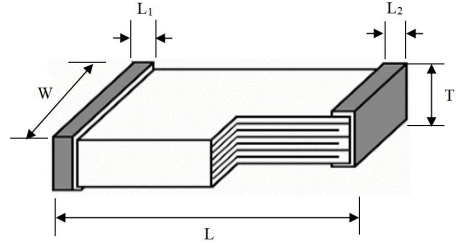

2、产品结构 Product Structure



图 1 片式多层陶瓷电容器外形与内部结构

Figure 1 Dimension and Cross-section of MLCC

四、温度系数/特性 Temperature Coefficient /Characteristics

介质种类 DIELECTRIC	参考温度点 REFERENCE TEMPERATURE POINT	标称温度系数 TEMPERATURE COEFFICIENT	工作温度范围 OPERATION TEMPERATURE RANGE
C0G	20 °C	0 ± 30 ppm/°C	-55°C ~ 125°C
C0H	20 °C	0 ± 60 ppm/°C	-55°C ~ 125°C
X5R	20 °C	± 15%	-55°C ~ 85°C
X6S	20 °C	± 22%	-55°C ~ 105°C
X7R	20 °C	± 15%	-55°C ~ 125°C
X7S	20 °C	± 22%	-55°C ~ 125°C

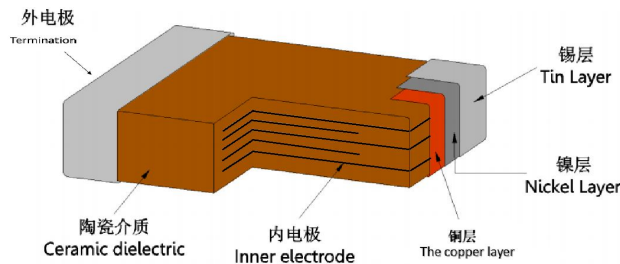
备注：I类介质电容器标称温度系数和允许偏差是采用温度在 20°C 和 85°C 之间的电容量变化来确定的，而II类介质电容器标称温度系数是按照工作范围之间的电容量相对 20°C 的电容量变化来确定的。

Note: Nominal temperature coefficient and allowed tolerance of class I are decided by the changing of the capacitance between 20°C and 85°C. Nominal temperature coefficient of class II are decided by the capacitance change at the testing temperature to 20°C.

利和兴电子元器件（江门）有限公司
Lihexing electronic components(Jiangmen) Co., Ltd
利容电子（江门）有限公司
Lirong electronic(Jiangmen) Co., Ltd

五、产品规格表示方法 Part Number Structure

LCN	0805	X7R	104	K	500	N	T	H
产品系列 Series	尺寸 Size	材质 Dielectric	标称容量 Capacitance	精度级别 Tolerance	脉冲电压 Impulse Voltage	端电极类型 Termination	包装方式 packaging	厚度代号 Thickness
①	②	③	④	⑤	⑥	⑦	⑧	⑨

① 产品系列 Series

代号	表示名称
L	利和兴
C	电容器
N	常规产品

② 尺寸规格 Size Specification(mm)

英制表示 BRITISH	长×宽 (L×W) INCH	长×宽 (L×W) MM
0201	0.02×0.01	0.60×0.30
0402	0.04×0.02	1.00×0.50
0603	0.06×0.03	1.60×0.80
0805	0.08×0.05	2.00×1.25
1206	0.12×0.06	3.20×1.60
1210	0.12×0.10	3.20×2.50
1808	0.18×0.08	4.50×2.00
1812	0.18×0.12	4.50×3.20

③ 介质种类 Dielectric Type

I类陶瓷介质	II类陶瓷介质
C0G、C0H	X7R、X7S、X5R、X6S
...	...

④ 静电容量 Capacitance

代号	表示值	静电容量	说明
R50	0.5	0.50pF	静电容量由3位字符表示。单位为皮法(pF)。第1位和第2位数字为有效数字,第3位数字表示有效数字后的0的个数。有小数点时以大写字母"R"表示。此时,所有数字均为有效数字。如果包含有任何不是"R"的字母,则表明该特指的品名是一个非标准的部件。 Nominal capacitance is represented by 3 digits, with the unit of picofarad (pF). The first and second digits are significant digits, and the third digit identifies the multiplier. When there is a decimal point, it is represented by a capital letter "R". At this time, all numbers are valid numbers. If it contains any letter other than "R", it indicates that the specified product name is a non-standard part.
1R0	1	1.0pF	
100	10	10pF	
102	10×10 ²	1000pF	
104	10×10 ⁴	10000pF	
...	

⑤ 静容量公差 Tolerance of Capacitance

代号	静容量公差	说明
B	±0.10pF	B、C、D 级误差适用于容量≤10pF 的产品 B, C, D level error is applicable to products with capacitance≤10pF
C	±0.25pF	
D	±0.50pF	
F	±1.0%	
G	±2.0%	
J	±5.0%	
K	±10%	
M	±20%	
S	+50% ~ -20%	

⑥ 额定电压 Rated Voltage

代号	表示值	额定电压	说明
6R3	6.3	DC6.3V	额定电压前面两位数字代表电压数字，第三位数字表示 0 的个数；R 代表小数点。 The first and second digits are significant digits of the rated voltage, and the third digit identifies the multiplier; R represents the decimal point.
100	10×10 ⁰	DC10V	
500	50×10 ⁰	DC50V	
201	20×10 ¹	DC200V	
102	10×10 ²	DC1000V	

⑦ 端电极类型 Termination Type

代号	端电极材料	注释
S	Ag 端电极	Ag/Ni/Sn
C	Cu 端电极	Cu/Resin
N	三层电镀端电极	Cu/Ni/Sn
R	软端子电极	Cu/树脂/Ni/Sn

⑧ 包装形式 Packing Code

代号	包装方式
T	纸带 paper tape
S	塑胶带 Embossed tape
B	散包装 Bulk packaging

⑨ 厚度代码 Thickness Code

代号	厚度尺寸 (T)	代号	厚度尺寸 (T)	代号	厚度尺寸 (T)
A	0.10mm	G	0.70mm	S	1.80mm
B	0.20mm	H	0.80mm	U	2.00mm
C	0.30mm	J	1.00mm	V	2.50mm
D	0.40mm	L	1.25mm	W	3.00mm
E	0.50mm	M	1.40mm	X	3.70mm
F	0.60mm	P	1.60mm		

六、产品范围、尺寸、厚度 Product Range、Size & Thickness

① I类介质电容范围 (C0G/C0H)

T.C 规格尺寸 额定电压 (V)	C0G, C0H															
	0201				0402				0603				0805			
	10	16	25	50	10	16	25	50	10	16	25	50	10	16	25	50
0.10pF (0R1)	C	C	C	C	E	E	E	E	H	H	H	H	G	G	G	G
0.20pF (0R2)	C	C	C	C	E	E	E	E	H	H	H	H	G	G	G	G
0.30pF (0R3)	C	C	C	C	E	E	E	E	H	H	H	H	G	G	G	G
0.40pF (0R4)	C	C	C	C	E	E	E	E	H	H	H	H	G	G	G	G
0.50pF (0R5)	C	C	C	C	E	E	E	E	H	H	H	H	G	G	G	G
0.60pF (0R6)	C	C	C	C	E	E	E	E	H	H	H	H	G	G	G	G
0.70pF (0R7)	C	C	C	C	E	E	E	E	H	H	H	H	G	G	G	G
0.80pF (0R8)	C	C	C	C	E	E	E	E	H	H	H	H	G	G	G	G
1.0pF (1R0)	C	C	C	C	E	E	E	E	H	H	H	H	G	G	G	G
1.2pF (1R2)	C	C	C	C	E	E	E	E	H	H	H	H	G	G	G	G
1.5pF (1R5)	C	C	C	C	E	E	E	E	H	H	H	H	G	G	G	G
1.8pF (1R8)	C	C	C	C	E	E	E	E	H	H	H	H	G	G	G	G
2.2pF (2R2)	C	C	C	C	E	E	E	E	H	H	H	H	G	G	G	G
2.7PF (2R7)	C	C	C	C	E	E	E	E	H	H	H	H	G	G	G	G
3.3pF (3R3)	C	C	C	C	E	E	E	E	H	H	H	H	G	G	G	G
3.9pF (3R9)	C	C	C	C	E	E	E	E	H	H	H	H	G	G	G	G
4.7pF (4R7)	C	C	C	C	E	E	E	E	H	H	H	H	G	G	G	G
5.6pF (5R6)	C	C	C	C	E	E	E	E	H	H	H	H	G	G	G	G
6.8pF (6R8)	C	C	C	C	E	E	E	E	H	H	H	H	G	G	G	G
8.2pF (8R2)	C	C	C	C	E	E	E	E	H	H	H	H	G	G	G	G
10pF (100)	C	C	C	C	E	E	E	E	H	H	H	H	G	G	G	G
12pF (120)	C	C	C	C	E	E	E	E	H	H	H	H	G	G	G	G
15pF (150)	C	C	C	C	E	E	E	E	H	H	H	H	G	G	G	G
18pF (180)	C	C	C	C	E	E	E	E	H	H	H	H	G	G	G	G
22pF (220)	C	C	C	C	E	E	E	E	H	H	H	H	G	G	G	G
27pF (270)	C	C	C	C	E	E	E	E	H	H	H	H	G	G	G	G
33pF (330)	C	C	C	C	E	E	E	E	H	H	H	H	G	G	G	G
39pF (390)	C	C	C	C	E	E	E	E	H	H	H	H	G	G	G	G
47pF (470)	C	C	C	C	E	E	E	E	H	H	H	H	G	G	G	G
56pF (560)	C	C	C	C	E	E	E	E	H	H	H	H	G	G	G	G
68pF (680)	C	C	C	C	E	E	E	E	H	H	H	H	G	G	G	G
82pF (820)	C	C	C	C	E	E	E	E	H	H	H	H	G	G	G	G
100pF (101)	C	C	C	C	E	E	E	E	H	H	H	H	G	G	G	G
120pF (121)	C	C	C	C	E	E	E	E	H	H	H	H	G	G	G	G
150pF (151)	C	C	C	C	E	E	E	E	H	H	H	H	G	G	G	G
180pF (181)	C	C	C	C	E	E	E	E	H	H	H	H	G	G	G	G
220pF (221)	C	C	C	C	E	E	E	E	H	H	H	H	G	G	G	G
270pF (271)	C	C	C	C	E	E	E	E	H	H	H	H	G	G	G	G
330pF (331)	C	C	C	C	E	E	E	E	H	H	H	H	G	G	G	G
390pF (391)	C	C	C	C	E	E	E	E	H	H	H	H	G	G	G	G
470pF (471)	C	C	C	C	E	E	E	E	H	H	H	H	G	G	G	G
560pF (561)	C	C	C	C	E	E	E	E	H	H	H	H	G	G	G	G
680pF (681)	C	C	C	C	E	E	E	E	H	H	H	H	G	G	G	G
820pF (821)	C	C	C	C	E	E	E	E	H	H	H	H	G	G	G	G
1.0nF (102)	C	C	C	C	E	E	E	E	H	H	H	H	H	H	H	H
1.2nF (122)					E	E	E	E	H	H	H	H	H	H	H	H
1.5nF (152)					E	E			H	H	H	H	H	H	H	H
1.8nF (182)					E	E			H	H	H	H	H	H	H	H
2.2nF (222)					E	E			H	H	H	H	H	H	H	H
2.7nF (272)					E	E			H	H	H	H	H	H	H	H
3.3nF (332)									H	H	H	H	H	H	H	H
3.9nF (392)									H	H	H	H	H	H	H	H
4.7nF (472)									H	H	H	H	H	H	H	H
5.6nF (562)									H	H	H	H	H	H	H	H
6.8nF (682)									H	H	H	H	H	H	H	H
8.2nF (822)									H	H			H	H	H	H
10nF (103)									H	H			L	L	L	L
22nF (223)									H							

利和兴电子元器件(江门)有限公司
 Lihexing electronic components(Jiangmen) Co., Ltd
 利容电子(江门)有限公司
 Lirong electronic(Jiangmen) Co., Ltd

① I类介质电容范围 (C0G/C0H)

T.C 规格尺寸	C0G, C0H															
	1206				1210				1808				1812			
额定电压 (V)	10	16	25	50	10	16	25	50	10	16	25	50	10	16	25	50
1.0pF (1R0)	G	G	G	G												
1.2pF (1R2)	G	G	G	G												
1.5pF (1R5)	G	G	G	G												
1.8pF (1R8)	G	G	G	G												
2.2pF (2R2)	G	G	G	G												
2.7pF (2R7)	G	G	G	G												
3.3pF (3R3)	G	G	G	G												
3.9pF (3R9)	G	G	G	G												
4.7pF (4R7)	G	G	G	G												
5.6pF (5R6)	G	G	G	G												
6.8pF (6R8)	G	G	G	G												
8.2pF (8R2)	G	G	G	G												
10pF (100)	G	G	G	G	L	L	L	L								
12pF (120)	G	G	G	G	L	L	L	L								
15pF (150)	G	G	G	G	L	L	L	L								
18pF (180)	G	G	G	G	L	L	L	L								
22pF (220)	G	G	G	G	L	L	L	L								
27pF (270)	G	G	G	G	L	L	L	L								
33pF (330)	G	G	G	G	L	L	L	L								
39pF (390)	G	G	G	G	L	L	L	L								
47pF (470)	G	G	G	G	L	L	L	L								
56pF (560)	G	G	G	G	L	L	L	L								
68pF (680)	G	G	G	G	L	L	L	L								
82pF (820)	G	G	G	G	L	L	L	L								
100pF (101)	G	G	G	G	L	L	L	L	L	L	L	L				
120pF (121)	G	G	G	G	L	L	L	L	L	L	L	L				
150pF (151)	G	G	G	G	L	L	L	L	L	L	L	L				
180pF (181)	G	G	G	G	L	L	L	L	L	L	L	L				
220pF (221)	G	G	G	G	L	L	L	L	L	L	L	L				
270pF (271)	G	G	G	G	L	L	L	L	L	L	L	L				
330pF (331)	G	G	G	G	L	L	L	L	L	L	L	L				
390pF (391)	G	G	G	G	L	L	L	L	L	L	L	L				
470pF (471)	G	G	G	G	L	L	L	L	L	L	L	L				
560pF (561)	G	G	G	G	L	L	L	L	L	L	L	L				
680pF (681)	G	G	G	G	L	L	L	L	L	L	L	L				
820pF (821)	G	G	G	G	L	L	L	L	L	L	L	L				
1nF (102)	H	H	H	H	L	L	L	L	L	L	L	L	L	L	L	L
1.2nF (122)	H	H	H	H	L	L	L	L	L	L	L	L	L	L	L	L
1.5nF (152)	H	H	H	H	L	L	L	L	L	L	L	L	L	L	L	L
1.8nF (182)	H	H	H	H	L	L	L	L	L	L	L	L	L	L	L	L
2.2nF (222)	H	H	H	H	L	L	L	L	L	L	L	L	L	L	L	L
2.7nF (272)	H	H	H	H	L	L	L	L	L	L	L	L	L	L	L	L
3.3nF (332)	H	H	H	H	L	L	L	L	L	L	L	L	L	L	L	L
3.9nF (392)	H	H	H	H	L	L	L	L	L	L	L	L	L	L	L	L
4.7nF (472)	H	H	H	H	L	L	L	L	L	L	L	L	L	L	L	L
5.6nF (562)	J	J	J	J	L	L	L	L	L	L	L	L	L	L	L	L
6.8nF (682)	J	J	J	J	L	L	L	L	L	L	L	L	L	L	L	L
8.2nF (822)	J	J	J	J	L	L	L	L	L	L	L	L	L	L	L	L
10nF (103)	L	L	L	L	U	U	U	U	P	P	P	P	P	L	L	L
22nF (223)	L	L	L	L	U	U	U	U	P	P	P	P	P	U	U	U
27nF (273)	L	L	L	L	U	U	U	U	P	P	P	P	P	U	U	U
33nF (333)	L	L	L	L	U	U	U	U	P	P	P	P	P	U	U	U
39nF (393)	L	L	L	L	U	U	U	U	P	P	P	P	P	U	U	U
47nF (473)	L	L	L	L	U	U	U	U	P	P	P	P	P	U	U	U
56nF (563)	L	L	L	L	U	U	U	U	P	P	P	P	P	U	U	U
68nF (683)	L	L	L	L	U	U	U	U	P	P	P	P	P	U	U	U
82nF (823)	L	L	L	L	U	U	U	U	P	P	P	P	P	U	U	U
100nF (104)	L	L	L	L	U	U	U	U	P	P	P	P	P	U	U	U

利和兴电子元器件(江门)有限公司
 Lihexing electronic components(Jiangmen) Co., Ltd
 利容电子(江门)有限公司
 Lirong electronic(Jiangmen) Co., Ltd

② II 类介质电容范围 (X7R)

T.C 规格尺寸 额定电压 V	X7R															
	0201				0402				0603				0805			
	10	16	25	50	10	16	25	50	10	16	25	50	10	16	25	50
100pF (101)	C	C	C	C		E	E				H	H			H	H
120pF (121)	C	C	C	C		E	E				H	H			H	H
150pF (151)	C	C	C	C		E	E				H	H			H	H
180pF (181)	C	C	C	C		E	E				H	H			H	H
220pF (221)	C	C	C	C		E	E				H	H			H	H
270pF (271)	C	C	C	C		E	E				H	H			H	H
330pF (331)	C	C	C	C		E	E				H	H			H	H
390pF (391)	C	C	C	C		E	E				H	H			H	H
470pF (471)	C	C	C	C		E	E				H	H			H	H
560pF (561)	C	C	C	C		E	E				H	H			H	H
680pF (681)	C	C	C	C		E	E				H	H			H	H
820pF (821)	C	C	C	C		E	E				H	H			H	H
1.0nF (102)	C	C	C	C	E	E	E	E			H	H	H	H	H	H
1.2nF (122)	C	C			E	E	E	E			H	H	H	H	H	H
1.5nF (152)	C	C			E	E	E	E			H	H	H	H	H	H
1.8nF (182)	C	C			E	E	E	E			H	H	H	H	H	H
2.2nF (222)	C	C			E	E	E	E			H	H	H	H	H	H
2.7nF (272)	C	C			E	E	E	E			H	H	H	H	H	H
3.3nF (332)	C	C			E	E	E	E			H	H	H	H	H	H
3.9nF (392)	C	C			E	E	E	E			H	H	H	H	H	H
4.7nF (472)	C	C			E	E	E	E			H	H	H	H	H	H
5.6nF (562)	C	C			E	E	E	E			H	H	H	H	H	H
6.8nF (682)	C	C			E	E	E	E			H	H	H	H	H	H
8.2nF (822)	C	C			E	E	E	E			H	H	H	H	H	H
10nF (103)	C	C			E	E	E	E	H	H	H	H	H	H	H	H
12nF (123)					E	E	E	E	H	H	H	H	H	H	H	H
15nF (153)					E	E	E	E	H	H	H	H	H	H	H	H
18nF (183)					E	E	E	E	H	H	H	H	H	H	H	H
22nF (223)					E	E	E	E	H	H	H	H	H	H	H	H
27nF (273)					E	E	E		H	H	H	H	H	H	H	H
33nF (333)					E	E	E		H	H	H	H	H	H	H	H
39nF (393)					E	E	E		H	H	H	H	H	H	H	H
47nF (473)					E	E	E		H	H	H	H	H	H	H	H
56nF (563)					E	E	E		H	H	H	H	H	H	H	H
68nF (683)					E	E	E		H	H	H	H	H	H	H	H
82nF (823)					E	E	E		H	H	H	H	H	H	H	H
100nF (104)					E	E	E		H	H	H	H	H	H	H	H
120nF (124)									H	H	H	H	H	H	H	H
150nF (154)									H	H	H	H	H	H	H	H
180nF (184)									H	H	H	H	H	H	H	H
220nF (224)					E				H	H	H	H	H	H	H	H
270nF (274)									H	H	H	H	H	H	H	H
330nF (334)									H	H	H	H	H	H	H	H
390nF (394)									H	H	H	H	H	H	H	H
470nF (474)									H	H	H	H	L	L	L	L
560nF (564)									H	H	H	H	L	L	L	L
680nF (684)									H	H	H	H	L	L	L	L
820nF (824)									H	H	H	H	L	L	L	L
1.0μF (105)									H	H	H	H	L	L	L	L
1.2μF (125)									H	H			L	L	L	L
1.5μF (155)									H	H			L	L	L	L
1.8μF (185)									H	H			L	L	L	L
2.2μF (225)									H	H			L	L	L	L
2.7μF (275)													L	L	L	L
3.3μF (335)													L	L	L	L
3.9μF (395)													L	L	L	L
4.7μF (475)													L	L	L	L
5.6μF (565)													L	L		
6.8μF (685)													L	L		
8.2μF (825)													L	L		
10μF (106)													L	L		
22μF (226)																
47μF (476)																

利和兴电子元器件(江门)有限公司
 Lihexing electronic components(Jiangmen) Co., Ltd
 利容电子(江门)有限公司
 Lirong electronic(Jiangmen) Co., Ltd

② II 类介质电容范围 (X7R)

T.C 规格尺寸	X7R															
	1206				1210				1808				1812			
额定电压 V	10	16	25	50	10	16	25	50	10	16	25	50	10	16	25	50
150pF (151)			H	H												
180pF (181)			H	H												
220pF (221)			H	H												
270pF (271)			H	H												
330pF (331)			H	H												
390pF (291)			H	H												
470pF (471)			H	H												
560pF (561)			H	H												
680pF (681)			H	H												
820pF (821)			H	H												
1.0nF (102)	H	H	H	H												
1.2nF (122)	H	H	H	H												
1.5nF (152)	H	H	H	H												
1.8nF (182)	H	H	H	H												
2.2nF (222)	H	H	H	H												
2.7nF (272)	H	H	H	H												
3.3nF (332)	H	H	H	H												
3.9nF (392)	H	H	H	H												
4.7nF (472)	H	H	H	H												
5.6nF (562)	H	H	H	H												
6.8nF (682)	H	H	H	H												
8.2nF (822)	H	H	H	H												
10nF (103)	H	H	H	H					L	L	L	L				
12nF (123)	H	H	H	H					L	L	L	L				
15nF (153)	H	H	H	H					L	L	L	L				
18nF (183)	H	H	H	H					L	L	L	L				
22nF (223)	H	H	H	H	J	J	J	J	L	L	L	L				
27nF (273)	H	H	H	H	J	J	J	J	L	L	L	L				
33nF (333)	H	H	H	H	J	J	J	J	L	L	L	L				
39nF (393)	H	H	H	H	J	J	J	J	L	L	L	L				
47nF (473)	H	H	H	H	J	J	J	J	L	L	L	L				
56nF (563)	H	H	H	H	J	J	J	J	L	L	L	L				
68nF (683)	H	H	H	H	J	J	J	J	L	L	L	L				
82nF (823)	H	H	H	H	J	J	J	J	L	L	L	L				
100nF (104)	H	H	H	H	J	J	J	J	L	L	L	L	L	L	L	L
120nF (124)	H	H	H	H	J	J	J	J	L	L	L	L	L	L	L	L
150nF (154)	H	H	J	J	J	J	J	J	L	L	L	L	L	L	L	L
180nF (184)	H	H	J	J	J	J	J	J	L	L	L	L	L	L	L	L
220nF (224)	H	H	J	J	J	J	J	J	L	L	L	L	L	L	L	L
270nF (274)	H	H	J	L	J	J	J	J	L	L	L	L	L	L	L	L
330nF (334)	H	H	J	L	J	J	J	L	L	L	L	L	L	L	L	L
390nF (394)	H	H	L	P	J	J	J	L	L	L	L	L	L	L	L	L
470nF (474)	H	H	L	P	J	J	J	L	L	L	L	L	L	L	L	L
560nF (564)	H	H	L	P	L	L	L	L	L	L	L	L	L	L	L	L
680nF (684)	H	H	L	P	L	L	L	L	L	L	L	L	L	L	L	L
820nF (824)	H	H	L	P	L	L	L	L	L	L	L	L	L	L	L	L
1.0μF (105)	L	L	L	P	L	L	L	L	L	L	L	L			U	U
1.2μF (125)	L	L	L	P	P	P	P	V								
1.5μF (155)	L	L	P		P	P	P	V								
1.8μF (185)	L	L	P	P	P	P	P	V								
2.2μF (225)	L	L	P	P	P	P	P	V								
2.7μF (275)	P	P	P	P	P	P	P	V								
3.3μF (335)	P	P	P		P	P										
3.9μF (395)	P	P	P	P												
4.7μF (475)	P	P	P	P	U	U	U	V								
5.6μF (565)	P	P	P													
6.8μF (685)	P	P			U	U										
8.2μF (825)	P	P	P		U	U										
10μF (106)	P	P	P		U	U										
22μF (226)	P	P			V	V										
47μF (476)					V											

利和兴电子元器件(江门)有限公司
 Lihexing electronic components(Jiangmen) Co., Ltd
 利容电子(江门)有限公司
 Lirong electronic(Jiangmen) Co., Ltd

③ II 类介质电容范围 (X7S)

T.C	X7S																			
规格尺寸	0402				0603				0805				1206				1210			
额定电压 V	6.3	10	16	25	6.3	10	16	25	10	16	25	50	10	16	25	50	10	16	25	50
680nF (684)		E																		
820nF (824)		E																		
1.0μF (105)		E										L								
1.8μF (185)																				
2.2μF (225)	E	E			H		H	H												
3.3μF (335)																				
4.7μF (475)					H	H	H				L		P	P	P	P				
8.2μF (825)																				
10μF (106)										L	L		P	P	P	P	U	U	U	U
22μF (226)													P	P			V	V	V	
47μF (476)													P				V	V		

④ II 类介质电容范围 (X6S)

T.C	X6S																			
规格尺寸	0402				0603				0805				1206				1210			
额定电压 V	6.3	10	16	25	6.3	10	16	25	6.3	10	16	25	10	16	25	50	10	16	25	50
470nF (474)	E																			
560nF (564)																				
680nF (684)																				
820nF (824)																				
1.0μF (105)	E	E	E	E																
1.2μF (125)																				
1.5μF (155)																				
1.8μF (185)																				
2.2μF (225)	E	E	E	E			H	H												
2.7μF (275)																				
3.3μF (335)																				
3.9μF (395)																				
4.7μF (475)	E				H	H	H	H			L	L								
5.6μF (565)																				
6.8μF (685)																				
8.2μF (825)																				
10μF (106)	E	E			H	H	H		L	L	L			P	P	P	V	V	V	
22μF (226)					H				L	L	L			P	P		V	V		
47μF (476)									L					P	P					

利和兴电子元器件(江门)有限公司
 Lihexing electronic components(Jiangmen) Co., Ltd
 利容电子(江门)有限公司
 Lirong electronic(Jiangmen) Co., Ltd

⑤ II 类介质电容范围 (X5R)

T.C 规格尺寸 额定电压 V	X5R																				
	0201				0402				0603				0805				1206				
	10	16	25	50	10	16	25	50	10	16	25	50	10	16	25	50	10	16	25	50	
82pF (820)		C	C	C																	
100pF (101)	C	C	C	C																	
120pF (121)	C	C	C	C																	
150pF (151)	C	C	C	C																	
180pF (181)	C	C	C	C																	
220pF (221)	C	C	C	C																	
270pF (271)	C	C	C	C																	
330pF (331)	C	C	C	C																	
390pF (391)	C	C	C	C																	
470pF (471)	C	C	C	C																	
560pF (561)	C	C	C	C																	
680pF (681)	C	C	C	C																	
820pF (821)	C	C	C	C																	
1.0 nF (102)	C	C	C	C																	
1.2nF (122)	C	C	C	C																	
1.5nF (152)	C	C	C	C																	
1.8nF (182)	C	C	C	C																	
2.2nF (222)	C	C	C	C																	
2.7nF (272)	C	C	C	C																	
3.3nF (332)	C	C	C	C																	
3.9nF (392)	C	C	C	C																	
4.7nF (472)	C	C	C	C																	
5.6nF (562)	C	C	C	C																	
6.8nF (682)	C	C	C	C																	
8.2nF (822)	C	C	C	C																	
10nF (103)	C	C	C	C																	
12nF (123)	C	C	C																		
15nF (153)	C	C	C																		
18nF (183)	C	C	C																		
22nF (223)	C	C	C																		
27nF (273)	C	C	C																		
33nF (333)	C	C	C																		
39nF (393)	C	C	C																		
47nF (473)	C	C	C																		
56nF (563)	C	C	C		E	E															
68nF (683)	C	C	C		E	E															
82nF (823)	C	C	C		E	E															
100nF (104)	C	C	C		E	E	E	E													
120nF (124)	C	C				E															
150nF (154)	C	C				E	E														
180nF (184)	C	C				E															
220nF (224)	C	C			E	E	E	E			H	H									
270nF (274)	C	C									H	H									
330nF (334)	C	C			E	E	E				H										
390nF (394)	C					E					H										
470nF (474)	C				E	E	E	E	H	H	H	H									
560nF (564)	C								H	H	H										
680nF (684)	C								H	H	H										
820nF (824)	C				E				H	H	H										
1.0μF (105)					E	E	E	E	H	H	H	H			L	L					
1.2μF (125)															L						
1.5μF (155)															L						
1.8μF (185)															L						
2.2μF (225)					E	E	E		H	H	H	H	L	L	L	L	P	P	P	P	
2.7μF (275)													L	L	L		P	P			
3.3μF (335)									H	H			L	L	L		P	P			
3.9μF (395)													L	L	L		P	P			
4.7μF (475)					E	E			H	H			L	L	L	L	P	P	P	P	
5.6μF (565)													L	L	L						
6.8μF (685)													L	L			P				
8.2μF (825)													L	L							
10μF (106)					E				H				L	L			P	P	P	P	
22μF (226)									H				L	L				P			
47μF (476)									H				L				P				

利和兴电子元器件(江门)有限公司
 Lihexing electronic components(Jiangmen) Co., Ltd
 利容电子(江门)有限公司
 Lirong electronic(Jiangmen) Co., Ltd

七、包装 Package

1、产品厚度和包装数量 Thickness and packing Amount

尺寸 Size	厚度代号 Thickness (mm)/Code		纸带 7"Reel paper Tape	胶带 7"Reel Embossed Tape
			Standard Qty(pcs)	Standard Qty(pcs)
0201	0.30±0.03	C	15000	20000
0402	0.50±0.05	E(C < 105)	10,000	-----
	0.50±0.20	E(C≥105)	10,000	-----
0603	0.80±0.10	H	4000	-----
0805	0.70±0.10	G	4000	-----
	0.80±0.10	H	4000	-----
	1.20±0.20	J	-----	3000
1206	0.70±0.10	G	4000	-----
	0.80±0.10	H	4000	-----
	1.00±0.10	I	-----	3000
	1.20±0.20	J	-----	3000
	1.60±0.20	L	-----	2000
1210	1.20±0.20	J	-----	2000
	1.60±0.20	L	-----	2000
	2.00±0.20	N	-----	2000
	2.50±0.30	O	-----	1000
1812	1.20±0.20	J	-----	1000
	1.60±0.20	L	-----	1000
	2.00±0.20	N	-----	1000
	2.50±0.30	O	-----	1000
	3.20±0.40	Q	-----	1000

2、带式圆盘包装 Tape and Reel package

带式圆盘包装在高速 SMT 生产中广泛应用.典型的直径为 180mm(7 英寸)的圆盘可以包装 1500-15000 粒电容, 直径为 330mm(13 英寸)的圆盘可以包装 10000-50000 粒电容.带式圆盘包装包括纸带包装、胶带包装两种方式。

Tape and reel packaging is currently the most popular system for high-speed SMT production, A typical 180mm(7inch)diameter reel contains 1500 to 15,000 capacitors,330mm(13inch)diameter reel contains 10,000 to 50,000 capacitors, Tape and reel packaging comprises paper tapes and embossed tapes.

3、纸带卷盘结构 Paper Taping

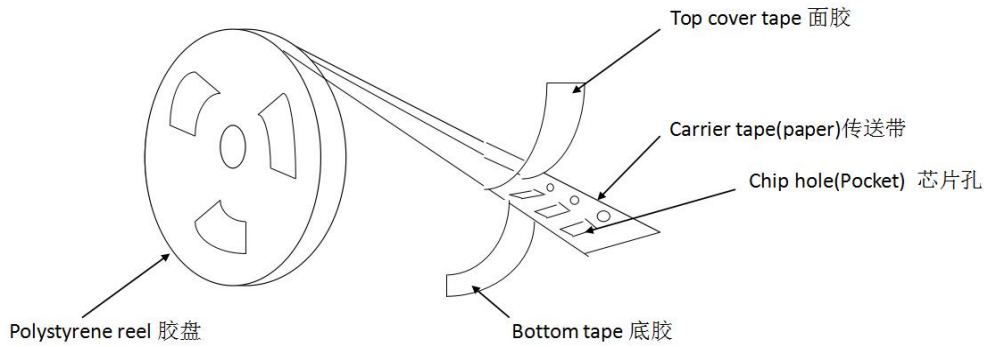

纸带标准 Paper Tape Specifications

适合 0201、0402、0603、0805、1206 常规产品的纸带尺寸。

Dimensions of paper taping for/0201, 0402, 0603, 0805, 1206 types.

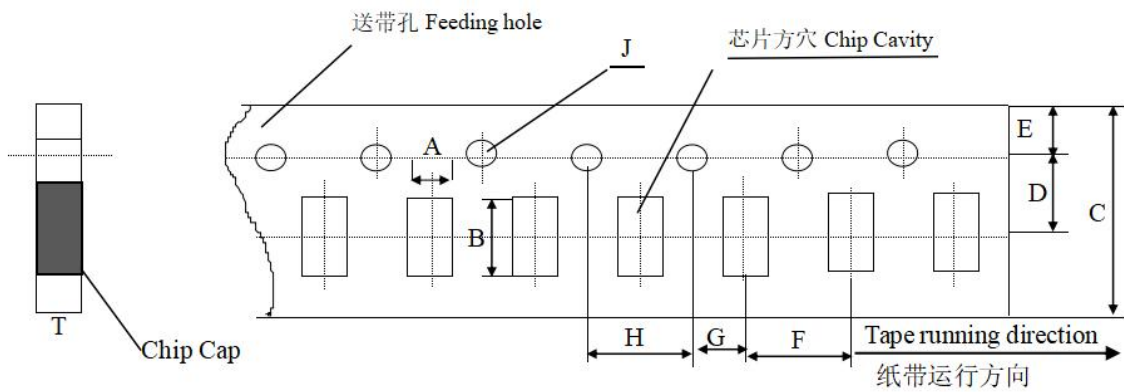

代号 Code 纸带规格 Paper size	A	B	C	D*	E	F	G*	H	J	T
0201	0.37 ±0.10	0.67 ±0.10	8.00 ±0.10	3.50 ±0.05	1.75 ±0.10	2.00 ±0.05	2.00 ±0.05	4.00 ±0.10	1.50 -0/+0.10	0.80 Below
0402	0.6 5±0.10	1.15 ±0.10	8.00 ±0.10	3.50 ±0.05	1.75 ±0.10	2.00 ±0.05	2.00 ±0.05	4.00 ±0.10	1.50 -0/+0.10	0.80 Below
0603	1.10 ±0.10	1.90 ±0.10	800 ±0.10	350 ±0.05	1.75 ±0.10	400 ±0.10	200 ±0.10	400 ±0.10	150 -0/+0.10	1.10 Max
0805	1.45 ±0.15	2.30 ±0.15	80 ±0.15	350 ±0.05	1.75 ±0.10	400 ±0.10	200 ±0.10	400 ±0.10	150 -0/+0.10	1.10 Max
1206	1.80 ±0.20	3.40 ±0.20	800 ±0.20	350 ±0.05	1.75 ±0.10	400 ±0.10	200 ±0.10	400 ±0.10	150 -0/+0.10	1.10 Max

注意：*表示此处对尺寸的要求非常精确。

Note: The place with "*" means where needs exactly dimensions

利和兴电子元器件(江门)有限公司
Lihexing electronic components(Jiangmen) Co., Ltd
利容电子(江门)有限公司
Lirong electronic(Jiangmen) Co., Ltd

4、塑胶卷盘结构 Embossed Taping

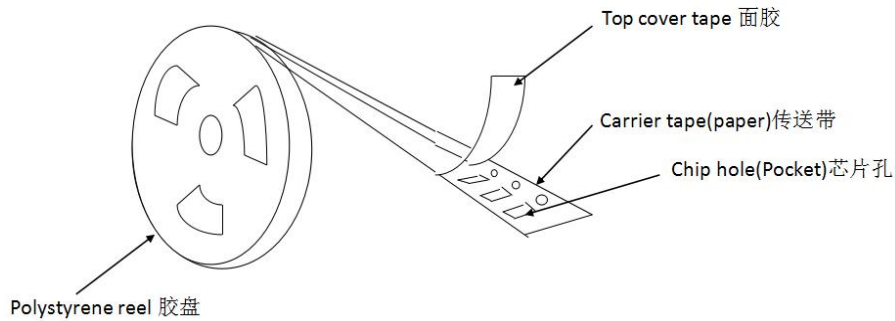

塑胶带标准 Embossed Tape Specifications

塑胶带尺寸结构适合‘0805~1812’型产品。

Dimensions of embossed taping for 0805~1812 type.

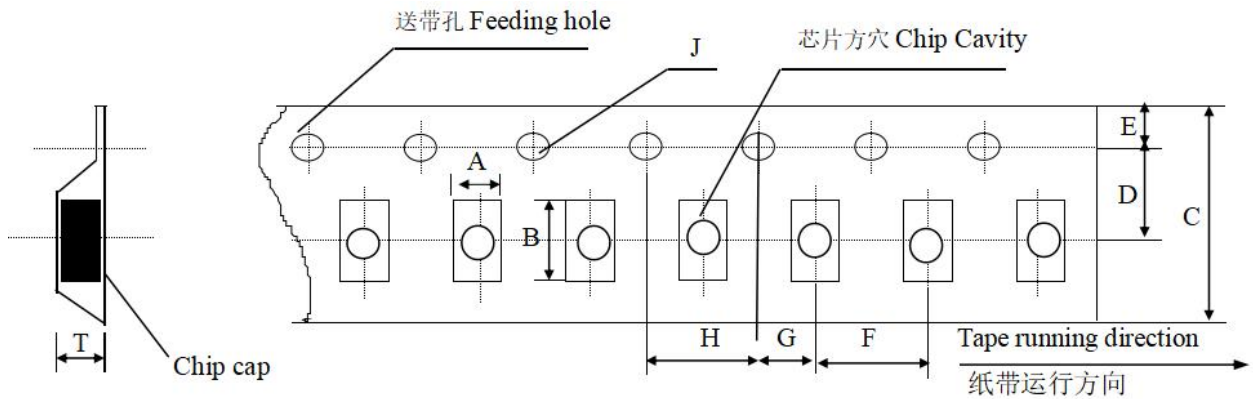

代号 Code 规格 Tape size	A	B	C	D*	E	F	G*	H	J	T
0805	1.55 ± 0.20	2.35 ± 0.20	8.00 ± 0.20	3.50 ± 0.05	1.75 ± 0.10	4.00 ± 0.10	2.00 ± 0.10	4.00 ± 0.10	1.50 -0/+0.10	1.50 Max
1206	1.95 ± 0.20	3.60 ± 0.20	8.00 ± 0.20	3.50 ± 0.05	1.75 ± 0.10	4.00 ± 0.10	2.00 ± 0.10	4.00 ± 0.1	1.50 -0/+0.10	1.85 Max
1210	2.70 ± 0.10	3.42 ± 0.10	8.00 ± 0.10	3.50 ± 0.05	1.75 ± 0.10	4.00 ± 0.10	2.00 ± 0.05	4.00 ± 0.10	1.55 -0/+0.10	3.2 Max
1808	2.20 ± 0.10	4.95 ± 0.10	12.00 ± 0.10	5.50 ± 0.05	1.75 ± 0.10	4.00 ± 0.10	2.00 ± 0.05	4.00 ± 0.10	1.50 -0/+0.10	3.0 Max
1812	3.66 ± 0.10	4.95 ± 0.10	12.00 ± 0.10	5.50 ± 0.05	1.75 ± 0.10	8.00 ± 0.10	2.00 ± 0.05	4.00 ± 0.10	1.55 -0/+0.10	4.0 Max

备注：*表示此处对尺寸的要求非常精确。

Note: The place with “*” means where needs exactly dimensions.

利和兴电子元器件（江门）有限公司
Lihexing electronic components(Jiangmen) Co., Ltd
利容电子（江门）有限公司
Lirong electronic(Jiangmen) Co., Ltd

5、传送带的前后结构 Front end and Back end Structure of Carrier Tape

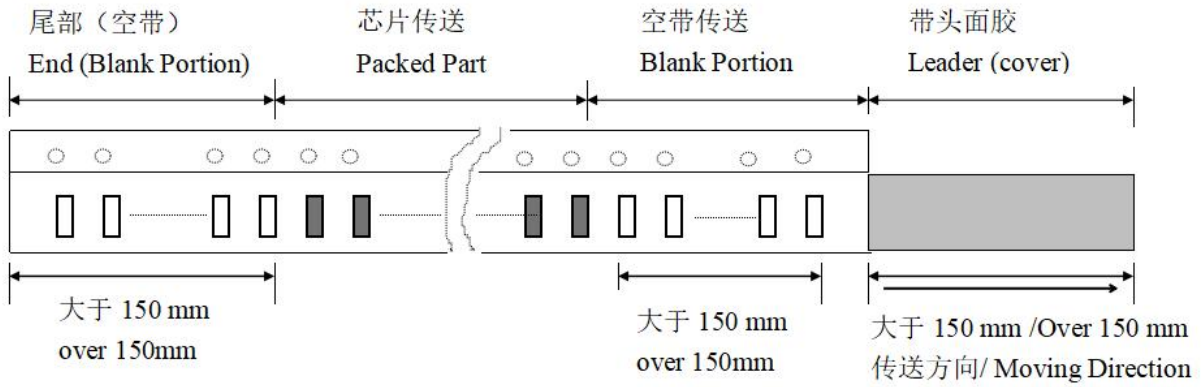

6、卷盘尺寸 Reel Dimensions (unit: mm)

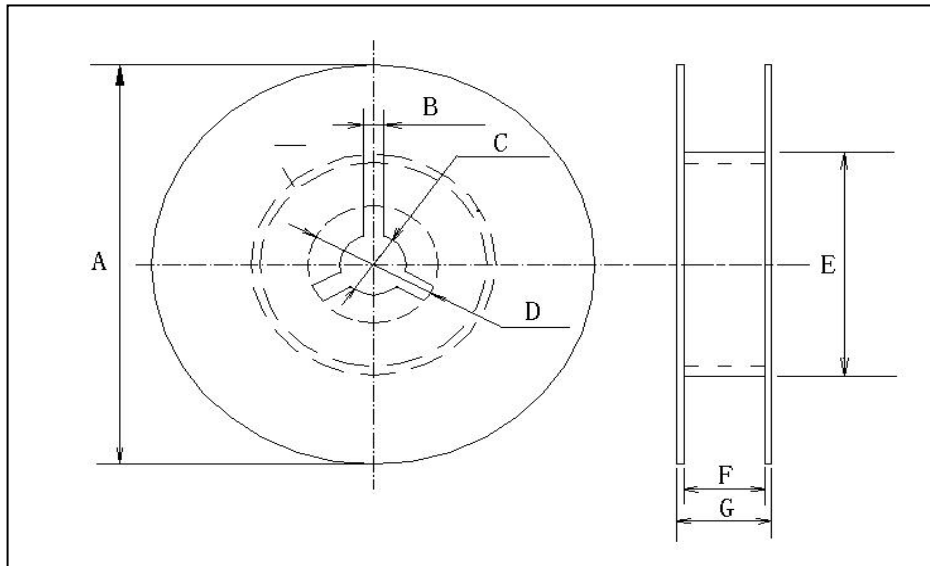

尺寸代码 (Code)

卷盘型号	A	B	C	D	E	F	G
7Reel	$\phi 178 \pm 2.0$	3.0	$\phi 13 \pm 0.5$	$\phi 21 \pm 0.8$	$\phi 50$ 或更大 $\phi 50$ or more	100 ± 1.5	12max
13Reel	$\phi 330 \pm 2.0$	3.0	$\phi 13 \pm 0.5$	$\phi 21 \pm 0.8$	$\phi 50$ 或更大 $\phi 50$ or more	100 ± 1.5	12max

7、纸带性能 Performance of Taping

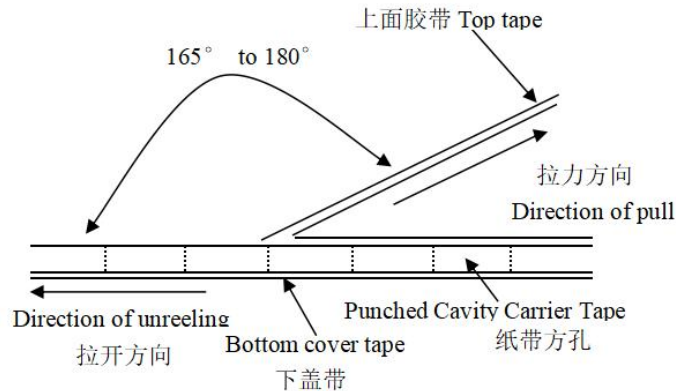

纸带和上盖带的剥离性能。Peeling Force of Carrier Tape and Top Cover Tape.

(b) 纸带在伸直状态下应该能经受 1.02kg 的压力。

The paper tape shall be able to withstand a pressure of 1.02kg in the straight state

(c) 上盖带应该能经受 1.02kg 的拉力。

The top cover tape should withstand 1.02kg of pull force

(d) 上盖带剥离强度 peeling Force of Top Cover Tape

除非有特殊规定，上盖带以 300mm/min 的速度，165~180°的角度（图 a）剥离纸带时，剥离力度应该在 10~60g 之间。

Unless otherwise specified, the peeling force of top cover tape shall be 10g to 60g when the top cover tape is pulled at a speed of 300mm/min with the angle between the taped during peeling and the direction of unreeing maintained at 165 to 180° as shown in figure (a).

8、外箱包装 Packing

小包装 The inner package

数量：10 卷

Quantity: 10 reels

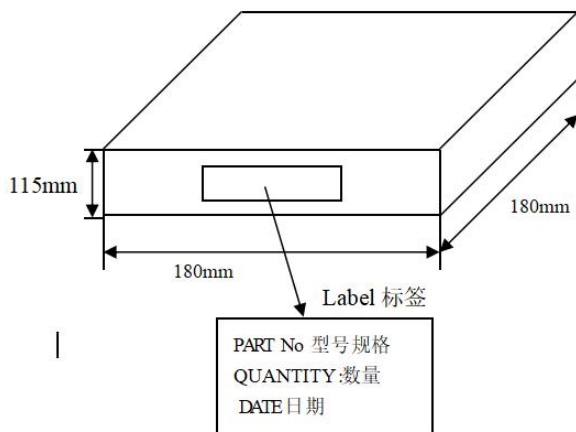

大包装 The outer package

数量：6 盒

Quantity: 6 inner boxes

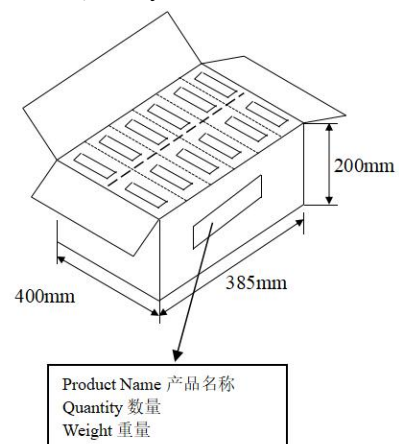

利和兴电子元器件（江门）有限公司
Lihexing electronic components(Jiangmen) Co., Ltd
利容电子（江门）有限公司
Lirong electronic(Jiangmen) Co., Ltd

八、储存方法 Storage Methods

确保芯片可焊性良好的贮存期限为 6 个月(在包装好已交付的情况下)。

The guaranteed period for solderability is 6 months (Under deliver package condition).

储存条件/Storage Conditions:

储存温度/Temperature 5~40°C

储存相对湿度/Relative Humidity 20~70%

九、使用前的注意事项 Precautions For Use

多层片式瓷介电容器(MLCC)在短路或开路的电路中都有可能失效,在超出本承认书或相关说明书中所述使用的恶劣工作环境,或外界机械力超压作用下,电容芯片都有可能着火、燃烧甚至爆炸,所以在使用的时候,首先应考虑按本承认书的有关说明来进行,如有不明之处,请联系厂家咨询。

The Multi-layer Ceramic Capacitors (MLCC) may fail in a short circuit or in an open circuit mode when subjected to severe conditions of electrical environment and / or mechanical stress beyond the specified “rating” and specified “conditions” in the specification, which will result in burn out, flaming or explosion in the worst case. Following “precautions for “safety” and Application Notes shall be taken in your major consideration.

1、焊接的条件与相关图表 Soldering profile

为避免因温度的突然变化而引起的芯片开裂或局部开裂的现象发生,请按有关温度曲线图表来进行。(请参考附页中的图表)

To avoid the crack problem by sudden temperature change, follow the temperature profile in the related graph. (refer to the graph in the enclosure page)

①手工焊接 Manual Soldering

手工焊接很容易因为芯片局部受热不均而引起瓷体微裂或局部开裂的现象,在焊接时,如果操作者不小心,会使烙铁头直接同电容芯片的瓷体部分接触,这样很容易使电容芯片因热冲击而受损或出现其他意外。因此,使用电烙铁手工焊接时应仔细操作,并对电烙铁的尖端的选择和尖端温度控制应多加小心。

Manual welding is easy to cause microcrack or partial cracking because of uneven heating of chip. The hot soldering iron tip comes into direct contact with the end terminations, and operator’s careless may cause the tip of the soldering iron to come into direct contact with the ceramic body of the capacitor. Therefore the soldering iron must be handled carefully, and pay much attention to the selection of the soldering iron tip and temperature contact of the tip.

② 适量的焊料 Optimum Solder Amount for Reflow Soldering

焊料过多

Too much solder

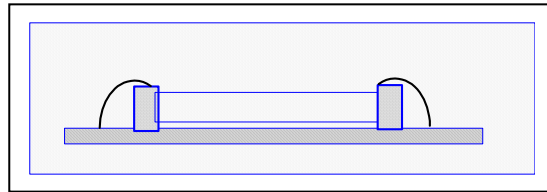

这样会因端头压力过大可能引起芯片受损。

Cracks tend to occur due to large stress.

焊料太少

Not enough solder

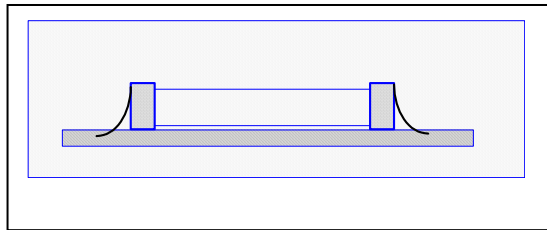

固定力量不足,可能会引起电容芯片与线路接触不良。

Weak holding force may cause bad connection between the capacitor and PCB.

2、推荐焊料用量 Recommended Soldering amounts

a.回流焊接的最佳焊料用量

The optimal solder amounts for re-flow soldering

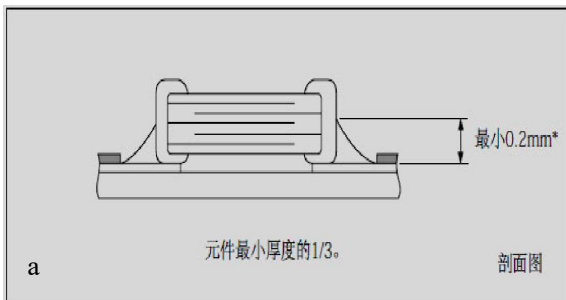

b.波峰焊接的最佳焊料用量

The optimal solder amounts for wave soldering

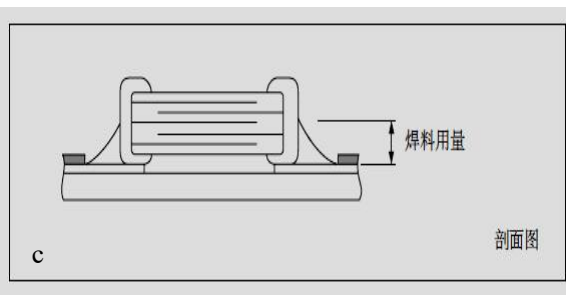
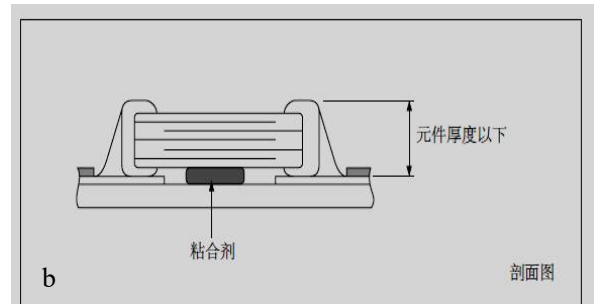

c.使用烙铁返修时的最佳焊料量

The optimal solder amounts for reworking by using soldering iron

十、推荐焊接温度曲线图 The temperature profile for soldering

(a) 回流焊接 (Re-flow soldering)

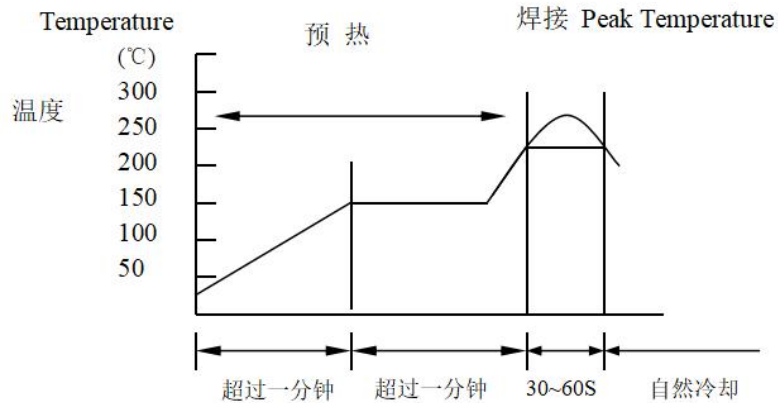

	Pb-Sn 焊接 Pb-Sn soldering	无铅焊接 Lead-free soldering
尖峰温度 Peak temperature	230°C ~ 250°C	240°C ~ 260°C

在预热时, 请将焊接温度与芯片表面温度之间的温差维持在 $T \leq 150^\circ\text{C}$ 。

While in preheating, please keep the temperature difference between soldering temperature and surface temperature of chips as: $T \leq 150^\circ\text{C}$.

(b) 波峰焊接 (Wave soldering)

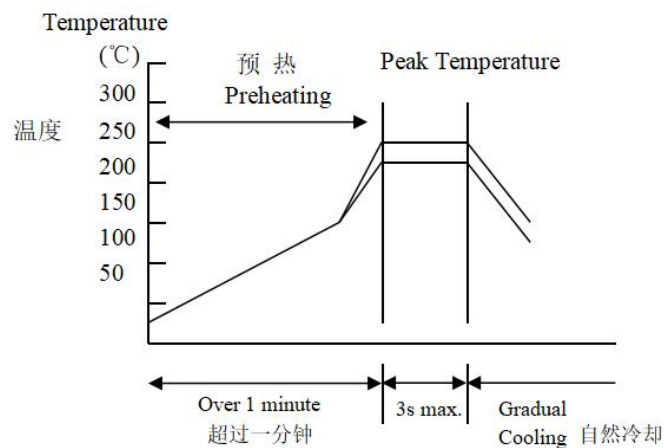

	pb-Sn 焊接 pb-Sn soldering	无铅焊接 Lead-free soldering
尖峰温度 peak temperature	230°C ~ 260°C	240°C ~ 270°C

在预热时, 请将焊接温度与芯片表面温度之间的温差维持在 $T \leq 150^\circ\text{C}$ 。

While in preheating, please keep the temperature difference between soldering temperature and surface temperature of chips as: $T \leq 150^\circ\text{C}$.

利和兴电子元器件(江门)有限公司
Lihexing electronic components(Jiangmen) Co., Ltd
利容电子(江门)有限公司
Lirong electronic(Jiangmen) Co., Ltd

十一、电气特性 Electrical Characteristics

电容量-温度特性 CAPACITANCE-TEMPERATURE CHARACTERISTICS

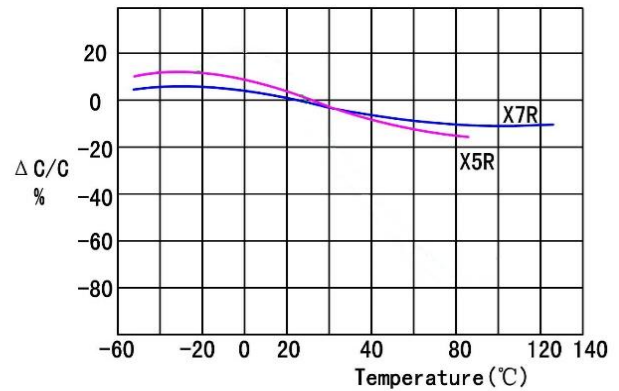
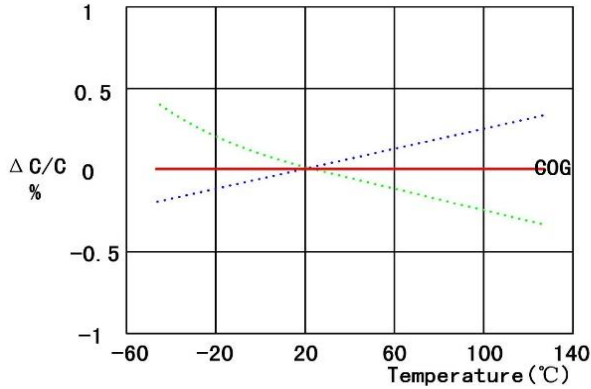

电容量-直流偏压特性 CAPACITANCE-DC VOLTAGE BIAS CHARACTERISTICS

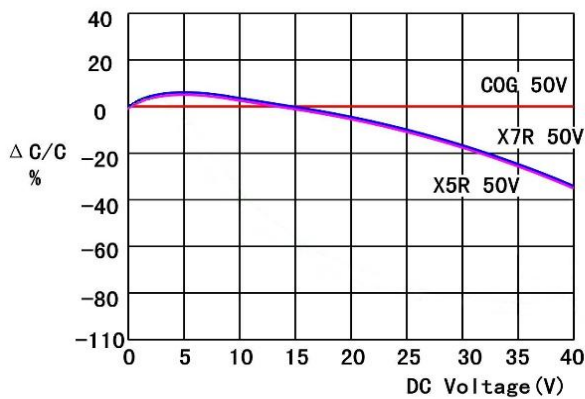

电容量老化特性 CAPACITANCE CHANGE-AGING

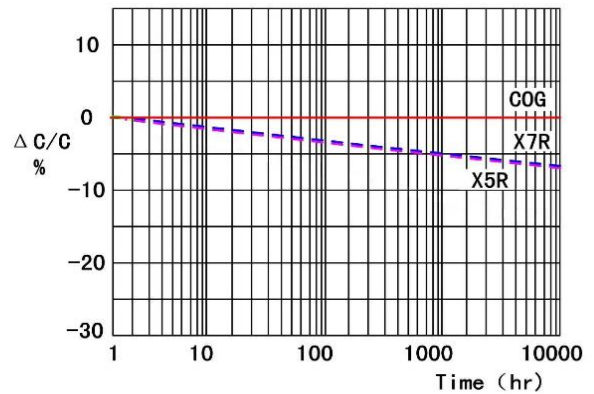

阻抗-频率特性 IMPEDANCE-FREQUENCY CHARACTERISTICS

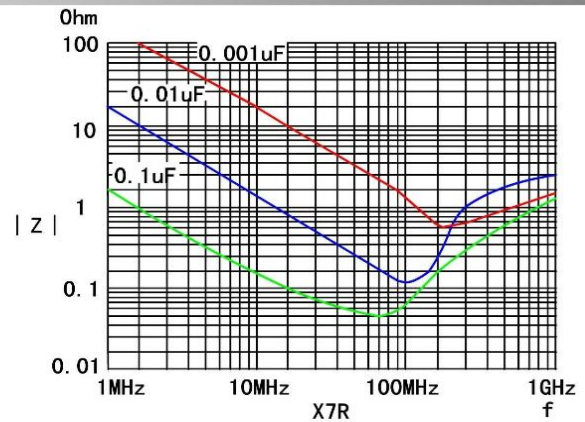
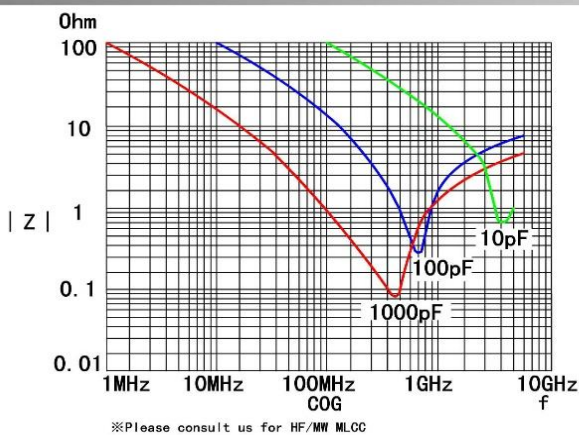

利和兴电子元器件(江门)有限公司
 Lihexing electronic components(Jiangmen) Co., Ltd
 利容电子(江门)有限公司
 Lirong electronic(Jiangmen) Co., Ltd

十二、性能测试方法

项目 Item	技术规格 Technical Specification		测试方法 Test Method and Remarks		
容量 Capacitance	I类 Class I	应符合指定的误差级别 Should be within the specified tolerance.	标称容量 Capacitance	测试频率 Measuring Frequency	测试电压 Measuring Voltage
			≤1000pF	1MHz±10%	1.0±0.2Vrms
			> 1000 pF	1KHz±10%	
	II类 Class II	应符合指定的误差级别 Should be within the specified tolerance.	测试温度: 25°C±3°C Test Temperature: 25°C±3°C C≤10μF: 测试频率: 1KHz±10% 测试电压: 1.0±0.2Vrms Test Frequency: 1KHz±10% Test Voltage: 1.0±0.2Vrms C > 10μF: X7R、X5R、X7S、X6S 测试频率: 120±24 Hz 测试电压: 0.5±0.1Vrms Test Frequency: 120±24 Hz Test Voltage: 0.5±0.1Vrms		
损耗角正切(DF, tanδ) Dissipation Factor	I类 Class I	DF	标称容量 Capacitance	测试频率 Measuring Frequency	测试电压 Measuring Voltage
		≤0.56%	Cr < 5 pF	1MHz±10%	1.0±0.2Vrms
		$1.5[(150/Cr)+7] \times 10^{-4}$	5pF≤Cr < 50 pF	1MHz±10%	
		≤0.10%	50pF≤Cr≤1000 pF	1MHz±10%	
		≤0.10%	> 1000 pF	1KHz±10%	

项目 Item	技术规格 Technical Specification					测试方法 Test Method and Remarks			
损耗角 正切 (DF,tan δ) Dissipa tion Factor	II类 Clas s II	X7R /X5 R X7S/ X6S (≥0 402)	≥50V	25V	16V	10V	6.3V	C≤10μF: 测试频率: 1KHz±10% 测试电压: 1.0±0.2Vrms Test Frequency: 1KHz±10% Test Voltage: 1.0±0.2Vrms C > 10μF 测试频率: 120±24 Hz 测试电压: 0.5±0.1Vrms Test Frequency: 120±24 Hz Test Voltage: 0.5±0.1Vrms	
			≤2.5% (C < 0.47μF)	≤3.5% (C < 0.47μF)	≤3.5% (C < 0.47μF)	≤10.0% (C≥0.47μF)	≤5.0% (C < 0.15μF)		≤5.0% (C < 0.15μF)
		X7R /X5 R X7S/ X6S (< 0402)	≤3.5%	≤5.0%	≤5.0% (C < 0.047 μF) ≤10% (C≥0.047μF)	≤5.0% (C < 0.047μF) ≤10% (C≥0.047μF)	≤5.0% (C < 0.047μF) ≤10% (C≥0.047μF)	Z5U:测试频率:1±0.1KHz 测试电压:0.5±0.05Vrms Test Frequency: 1±0.1KHz Test Voltage: 0.5±0.05Vrms	
绝缘电 阻(IR) Insulati on Resista nce	I类 Clas s I	C≤10nF, Ri≥50000MΩ C > 10nF, Ri•CR≥500S					测试电压:额定电压 测试时间: 60±5 秒 测试湿度: ≤75% 测试温度: 25°C±3°C 测试充放电电流: ≤50mA Measuring Voltage: Rated Voltage Duration: 60±5s Test Humidity: ≤75% Test Temperature: 25°C±3°C Test Current: ≤50mA		
	II类 Clas s II	C≤25nF, Ri≥10000MΩ C > 25nF, Ri•CR > 100S							
介质耐 电强度 (DWV) Dielectr ic Withsta nding Voltage	不应有介质被击穿或损伤 No break down or damage.					测量电压: I类: 300%额定电压 II类: 250%额定电压 时间: 1~5 秒 充/放电电流: 不应超过 50mA (这部分说明不包括中高压 MLCC) Measuring Voltage: ClassI:300% Rated voltage ClassII:250% Rated voltage Duration: 1~5s Charge/ Discharge Current: 50mA max. (This method excludes high-voltage MLCC)			

项目 Item	技术规格 Technical Specification		测试方法 Test Method and Remarks
可焊性 Solderability	上锡率应大于 95% 外观无可见损伤。 At least 95% of the terminal electrode is covered by new solder. Visual Appearance: No visible damage.		将电容在 80~120°C 的温度下预热 10~30 秒。 Preheating Conditions: 80 to 120°C; 10~30s.
			有铅焊料: (Sn/pb : 63/37) 浸锡温度: 235±5°C 浸锡时间: 2±0.5s Solder Temperature: 235±5°C Duration: 2±0.5s
耐焊接热 Resistance to Soldering Heat	项目 Item	NP0 至 SL NP0 to SL	X7R/X5R/ X7S/X6S
	ΔC/C	≤±0.5%或±0.5pF, 取较大值 ≤±0.5% or ±0.5pF, whichever is larger	-5~+10%
	DF	同初始标准 Same to initial value.	
	IR	同初始标准 Same to initial value.	
	外观: 无可见损伤 上锡率: ≥95% Appearance: No visible damage. At least 95% of the terminal electrode is covered by new solder.		将电容在 100~200°C 的温度下预热 10±2 分钟。 浸锡温度: 265±5°C 浸锡时间: 10±1s 然后取出溶剂清洗干净, 在 10 倍以上的显微镜底下观察。 放置时间: 24±2 小时 放置条件: 室温 Preheating Conditions: 100 to 200°C; 10±2min. Solder Temperature: 265±5°C Duration: 10±1s Clean the capacitor with solvent and examine it with a 10X(min.) microscope. Recovery Time: 24±2h Recovery Condition: Room temperature
抗弯曲强度 Bending Strength	外观: 无可见损伤。 Appearance: No visible damage.		试验基板: PCB 弯曲深度: 1mm 施压速度: 0.5mm/sec. 单位: mm 应在弯曲状态下进行测量。
	ΔC/C	≤±10%	

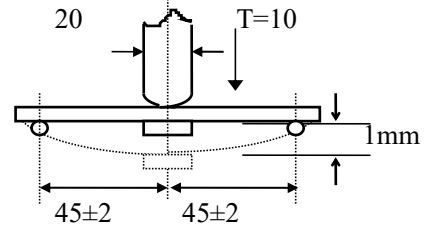

项目 Item	技术规格 Technical Specification	测试方法 Test Method and Remarks																														
温度循环 Temperature Cycle	$\Delta C/C$: I类: $\leq \pm 1\%$ 或 $\pm 1pF$, 取两者中最大者 II类: X7R\X7S\X6S\X5R: $\leq \pm 10\%$ E, F: $\leq \pm 20\%$ Class I: $\leq \pm 1\%$ or $\pm 1pF$, whichever is larger. Class II: X7R\X7S\X6S\X5R: $\leq \pm 10\%$ E, F: $\leq \pm 20\%$	预处理* (2类): 上限温度, 1小时, 恢复: 24±1h 初始测量 循环次数: 5次, 一个循环分以下4步: <table border="1" data-bbox="890 409 1422 772"> <thead> <tr> <th>阶段</th> <th>温度 (°C)</th> <th>时间 (分钟)</th> </tr> </thead> <tbody> <tr> <td>第1步</td> <td>下限温度 (X7R/X7S/X6S/X5R: -55°C)</td> <td>30</td> </tr> <tr> <td>第2步</td> <td>常温 (+20°C)</td> <td>2~3</td> </tr> <tr> <td>第3步</td> <td>上限温度 (NP0/X7R/X7S: +125 X6S: +105°C)</td> <td>30</td> </tr> <tr> <td>第4步</td> <td>常温 (+20°C)</td> <td>2~3</td> </tr> </tbody> </table> 试验后放置 (恢复) 时间: 24±2h Preheating Conditions: Up-Limit temperature, 1h Recovery Time: 24±1h Initial Measurement Cycling Times: 5 times, 1 cycle, 4 steps: <table border="1" data-bbox="890 965 1406 1359"> <thead> <tr> <th>Step</th> <th>Temperature (°C)</th> <th>Time (min.)</th> </tr> </thead> <tbody> <tr> <td>1</td> <td>Low-Limit temp. (X7R/X7S/X6S/X5R: -55°C)</td> <td>30</td> </tr> <tr> <td>2</td> <td>Normal temp. (+20)</td> <td>2~3</td> </tr> <tr> <td>3</td> <td>Up-Limit temp. (NP0/X7R/X7S: X6S: +105)</td> <td>30</td> </tr> <tr> <td>4</td> <td>Normal temp. (+20)</td> <td>2~3</td> </tr> </tbody> </table> Recovery time after test: 24±2h	阶段	温度 (°C)	时间 (分钟)	第1步	下限温度 (X7R/X7S/X6S/X5R: -55°C)	30	第2步	常温 (+20°C)	2~3	第3步	上限温度 (NP0/X7R/X7S: +125 X6S: +105°C)	30	第4步	常温 (+20°C)	2~3	Step	Temperature (°C)	Time (min.)	1	Low-Limit temp. (X7R/X7S/X6S/X5R: -55°C)	30	2	Normal temp. (+20)	2~3	3	Up-Limit temp. (NP0/X7R/X7S: X6S: +105)	30	4	Normal temp. (+20)	2~3
阶段	温度 (°C)	时间 (分钟)																														
第1步	下限温度 (X7R/X7S/X6S/X5R: -55°C)	30																														
第2步	常温 (+20°C)	2~3																														
第3步	上限温度 (NP0/X7R/X7S: +125 X6S: +105°C)	30																														
第4步	常温 (+20°C)	2~3																														
Step	Temperature (°C)	Time (min.)																														
1	Low-Limit temp. (X7R/X7S/X6S/X5R: -55°C)	30																														
2	Normal temp. (+20)	2~3																														
3	Up-Limit temp. (NP0/X7R/X7S: X6S: +105)	30																														
4	Normal temp. (+20)	2~3																														
潮湿试验 Moisture Resistance	$\Delta C/C$: I类: $\leq \pm 2\%$ 或 $\pm 1pF$, 取两者之中较大者 II类: X7R\X7S\X6S\X5R: $\leq \pm 10\%$ E, F: $\leq \pm 30\%$ Class I: $\leq \pm 2\%$ or $\pm 1pF$, whichever is larger. Class II: X7R\X7S\X6S\X5R: $\leq \pm 10\%$ E, F: $\leq \pm 30\%$ DF: ≤ 2 倍初始标准 Not more than twice of initial value. IR: I类: $R_i \geq 2500M\Omega$ 或 $R_i \cdot C_R \geq 25S$ 取两者之中较小者. Class I: $R_i \geq 2500M\Omega$ 或 $R_i \cdot C_R \geq 25S$ whichever is smaller. II类: $R_i \geq 1000M\Omega$ 或 $R_i \cdot C_R \geq 25S$ 取两者之中较小者. Class II: $R_i \geq 1000M\Omega$ 或 $R_i \cdot C_R \geq 25S$ whichever is smaller.	温度: 40±2°C 湿度: 90~95%RH 时间: 500小时 放置条件: 室温 放置时间: 24小时(I类); 48小时(II类) Temperature: 40±2°C Humidity: 90~95%RH Duration: 500h Recovery Conditions: Room temperature Recovery Time: 24h (Class1) or 48h (Class2)																														
	外观: 无损伤 Appearance: No visible damage.																															

项目 Item	技术规格 Technical Specification		测试方法 Test Method and Remarks
寿命试验 Life Test	*Δ C/C	I类: $\leq \pm 2\%$ 或 $\pm 1\text{pF}$ 取两者之中较大者 II类: X7R\X7S\X6S\X5R: $\leq \pm 20\%$ E,F: $\leq \pm 30\%$ Class I : $\leq \pm 2\%$ or $\pm 1\text{pF}$, whichever is larger. Class II : X7R\X7S\X6S\X5R: $\leq \pm 20\%$ E,F: $\leq \pm 30\%$	低压产品 < 100V 电压: 1.5 倍额定工作电压 时间: 1000 小时 *温度: 125°C (NP0、X7R) 85°C (X5R) 充电电流: 不应超过 50mA 放置条件: 室温 放置时间: 24 小时 (I类) 或 48 小时 (II类), Low-Voltage < 100V
	DF	≤ 2 倍初始标准 Not more than twice of initial value	Applied Voltage: $1.5 \times$ Rated voltage Duration: 1000h *Temperature: 125°C (NP0、 X7R) 85°C (X5R) Charge/ Discharge Current: 50mA max. Recovery Conditions: Room temperature Recovery Time: 24h (Class 1), or 48h (Class2)
	IR	I类: $R_i \geq 4000\text{M}\Omega$ 或 $R_i \cdot CR \geq 40\text{S}$ 取两者之中较小者. Class I: $R_i \geq 4000\text{M}\Omega$ 或 $R_i \cdot CR \geq 40\text{S}$ whichever is smaller	
外观: 无损伤 Visual Appearance: No visible damage			

*注解:

专门预处理 (仅对 2 类电容器): 将电容器放在上限温度或按详细规范中可能规定的更高温度下经 1h 后, 接着在试验的标准大气压条件下恢复 $24 \pm 1\text{h}$ 。

Note: Pretreatment (only for class2 capacitor)

Pretreatment (only for class2 capacitor) is a method to treat the capacitor before measurement. First, place the capacitor in the up-limit temperature or other specified higher temperature environment for 1hour. Then recovery the capacitor at standard atmospheric pressure conditions for $24 \pm 1\text{hours}$ 。